

V
来源

1-01BXXX-07Z1-JS
SP-T240-xxxBTQ-1

A4 零 部 件 图 纸

发
放
编
号

SP

AGENCY APPROVALS
* UL5085-1,UL5085-3, FILE NO.: E331579
* UL1446, FILE NO.: E304641

NOMINAL SPECIFICATIONS:

- Power: 20VA
- Input voltage: SEE TABLE
- Output:
 - No-load secondary voltage: 27.5VAC+/-5%
 - Load voltage @ Current (VAC @ A): 24.0VAC +/-5%@ 0.833A
 - Lead color: SEE NOTE
- Insulation class: B (130)
- Winding Protection: Inherently limiting.
- Temperature Protection: 130°C thermal link with secondary circuit.
- Dielectric Voltage-Withstand Test:
 - 2200V between the primary circuit and core
 - 2500V between the primary and secondary circuit
 - 500 V between secondary circuit and core
- Excitation power: 4.5W MAX.
- Dimensions for reference only. (UNIT: mm [inch])

Model	Primary		Secondary	
	See Note 1 for Terminal Number information		Pin 4-5	
	Frequency, Hz	Volt, V ac	Volt, V ac	Power, VA
T240-021Bydzzz	50/60	120	24	20
T240-071Bydzzz	50/60	240	24	20
T240-241Bydzzz	50/60	120/240	24	20
T240-271Bydzzz	50/60	208/240	24	20
T240-131Bydzzz	50/60	460	24	20
T240-151Bydzzz	50/60	575	24	20
T240-2K1Bydzzz	50/60	460/575	24	20

NOMENCLATURE:

- y = (T, G), bracket type
T denote for bracket
G denote for without bracket
- d = (Q1, Q2 or Q3) input/ output connection type
Q1 denote for Pin type terminals 250(0.81 mm thick and 6.35 mm wide)
Q2 denote for Pin type terminals 187(0.51 mm thick and 4.75 mm wide)
Q3 denote for Pin type terminals:
primary 187(0.51 mm thick and 4.75 mm wide);
secondary 250(0.81 mm thick and 6.35 mm wide)
- zzz = (000-999), denote for Customer ID Suffix

NOTE:

1. Terminal Number:

Primary Voltage	COM.	120V	208V	240V	460V	575V
Terminal Number	Pin 1	Pin 2	Pin 2	Pin 3	Pin 2	Pin 3
Secondary Voltage	COM.	24V				
Terminal Number	Pin 4	Pin 5				

2. Terminal: SEE NOMENCLATURE

3. Maybe remove the bracket according to customer requirements (Type G Panel Mount).

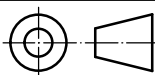
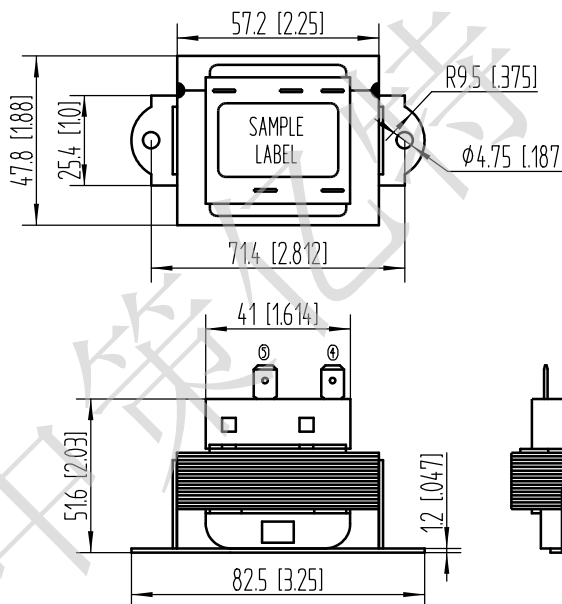

第三角投影法
THIRD ANGLE PROJECTION



宁波中策亿特电子有限公司
NINGBO ZHONGCE E.T ELECTRONICS CO LTD

宁波市望春工业园区聚才路189号
189 Jucai Rd, Wangchun Industrial Park
NINGBO CHINA

本图包含的设计及其他信息的所有权归宁波中策亿特电子有限公司。图纸或信息的全部或部分的复制、分发、使用或者公开，必须由宁波中策亿特电子有限公司的书面许可。

UNLESS OTHERWISE INDICATED, ALL DIMENSIONS ARE IN MILLIMETER. 除非另有陈述，所有尺寸均以毫米(mm)为单位。

TOLERANCES(公差):

- X = ± 0.3
- XX = ± 0.1
- XXX = ± 0.05
- X° = ± 0.5°

产品规格书 SPECS

规格书编号	SP-T240-xxxBTQ-1	版本	A
产品图号	/		
品号	/		
品名	/		
规格型号			
比例	NTS	重量	页码 1 OF 1

设计	瞿文军 2012-12-15	标准化	
制图	瞿文军 2012-12-15		
审核	黄力 2012-12-15		
工艺		批准	

借(通)用
件登记

旧底图总号

底图总号

签字

日期

档案员 日期 A 初始版本发行.

2012-12-15 瞿文军

版本号 变更描述 设计(变更)日期 设计(变更)